

# PACSystems VersaSafe

## Distributed Safety System with High Availability

At GE Intelligent Platforms, we understand that production has to become more efficient by enabling the operator to work closer to the process without compromising operator safety.

VersaSafe adds SIL3 machine safety capabilities to GE's high performance platforms strategy. By combining secure network connectivity, certified safety function blocks, an easy to use graphical programming environment, customers can efficiently integrate standards-compliant safety capabilities to their equipment while meeting increasingly stringent regulatory requirements.

In addition to enabling safety functionality, VersaSafe provides enhanced I/O control capabilities suitable for optimization of high-end machines.

### Higher availability

The VersaSafe distributed safety system provides a TÜV-certified SIL3 machine safety solution that focuses on the critical control requirements of the production environment: safe operation and greater uptime of the manufacturing equipment.

High availability is delivered by integrating industry-proven PROFINET with optional media redundant protocol (MRP) and multiple cable media options. Machine repair times are reduced by the ability to put a machine in a safe state without fully powering down the equipment, enabling faster start-up after a repair.

### Simplified architecture

VersaSafe is a member of the PACSystems control family that delivers increased performance, greater uptime and lower total cost of ownership. Leveraging PACSystems' distributed I/O architecture and single point of connect capabilities, VersaSafe enables efficient development of high-performance modular machines.

A single network carries standard and safety I/O; this simplifies wiring without compromising safety.

### Simplified engineering

To minimize engineering efforts, GE provides a comprehensive set of tools and services as part of the VersaSafe solution, including a library of certified safety function blocks, the ability to seamlessly integrate safety and standard capabilities and a robust set of integrated development and commissioning diagnostic utilities.

### Best-in-class scalability

GE has eliminated the need for a separate safety CPU, enabling a highly distributed safety I/O configuration that is both cost-effective and maintains highest levels of performance as the system grows. GE has also addressed customers' needs to make online changes to safety logic. Large production lines, in particular, will realize considerable benefit in the ability to update a portion of the safety logic without stopping the controller. Smaller machines benefit from right-sizing the safety I/O needs without bearing the overhead of a separate safety controller.

FEATURE	BENEFIT
Powerful integration tools	Faster engineering, commissioning, and reduced training
Complete library of safety function blocks	Simplified safety engineering due to pre-certified safety logic
Extensive safety diagnostics	Shorter time-to-market
Distributed safety architecture	"One solution fits all" scalability
PROFINET/PROFIBUS connectivity	Distributed safe communication via an open standard network
Redundant fiber network (MRP)	High availability in harsh industrial environments



# PACSystems VersaSafe – Distributed Safety System with High Availability

## Comprehensive module range

### Flexible Network Interfaces

- PROFINET: 100Mbit
- Copper, fiber, cable redundancy
- PROFIBUS DP V1

### Safety I/O

- Integrated pulse output
- Configurable pulse generation
- Integrated configurable timer
- Safe digital input, 24 VDC
- Safe digital output, 24 VDC, 2 A
- Safe output, relay 4 A, 2 contacts
- Configuration of dual channel or single channel

### Standard I/O (VersaPoint)

VersaSafe also provides a wide range of discrete, analog and special purpose standard I/O.

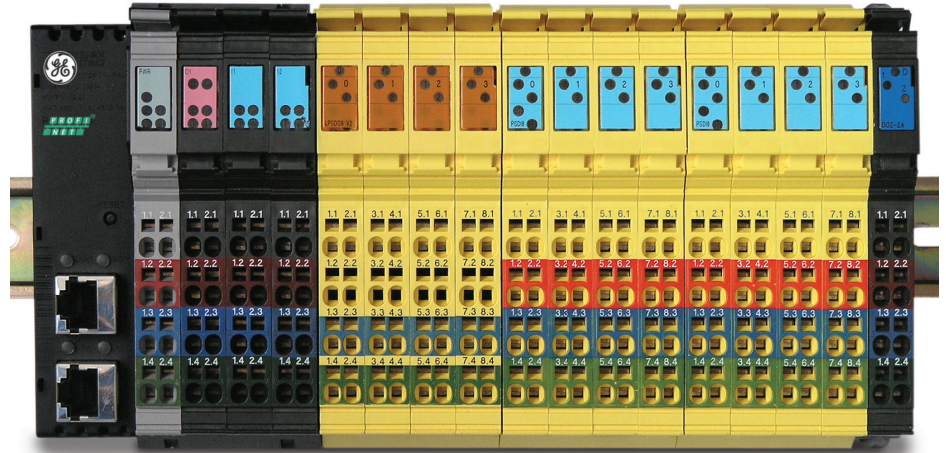

## Integrated tools enable simplified creation of safety logic

- Extensive list of pre-certified safety function blocks
- Simulation of safety logic
- Combination of safe logic and standard logic
- Easy-to-use and flexible configuration
- Tools to validate and document the safety project
- Graphical BOM configurator

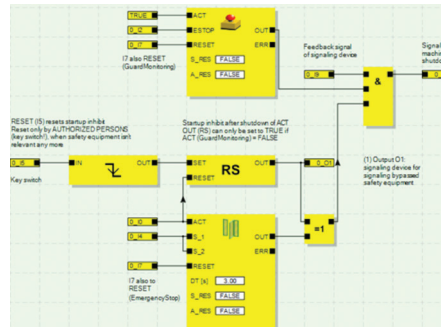

Easy Programming with Graphic Tools

### GLOBAL STANDARDS

- CE, UL, CUL approved
- Maximum Safety Levels:
  - IEC 61508: SIL 2, SIL 3
  - IEC62061: SIL CL 3
  - ISO 13849-1: PL d, PL e
  - Category: Cat 2, Cat. 4
- Safety level depends on configuration and wiring
- Operation temperature: -25°C to +55°C

The VersaSafe family of PROFINET-based safe I/O is part of GE Intelligent Platforms' High Performance Platform strategy that leverages industry standards plus the combination of our experience in embedded technology and automation to deliver long-life, high-performance solutions that are easy to configure, manage and upgrade. Contact our local representative for more information about GE's solutions for SIL3 safety requirements.

### GE Intelligent Platforms Contact Information

Americas: 1 800 433 2682 or 1 434 978 5100

Global regional phone numbers are listed by location on our web site at [www.ge-ip.com/contact](http://www.ge-ip.com/contact)

[www.ge-ip.com](http://www.ge-ip.com)

